

SECTION VIEWING UP-STATION

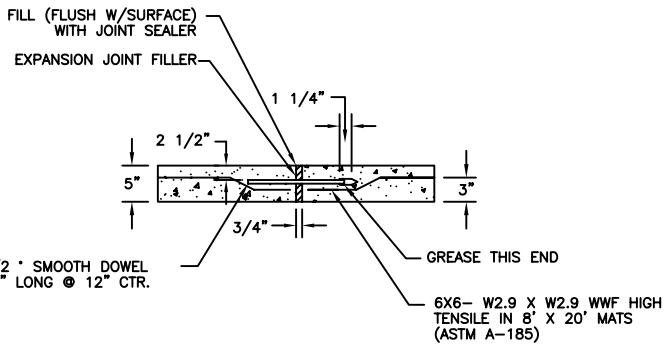

TYPE A
EXPANSION JOINT

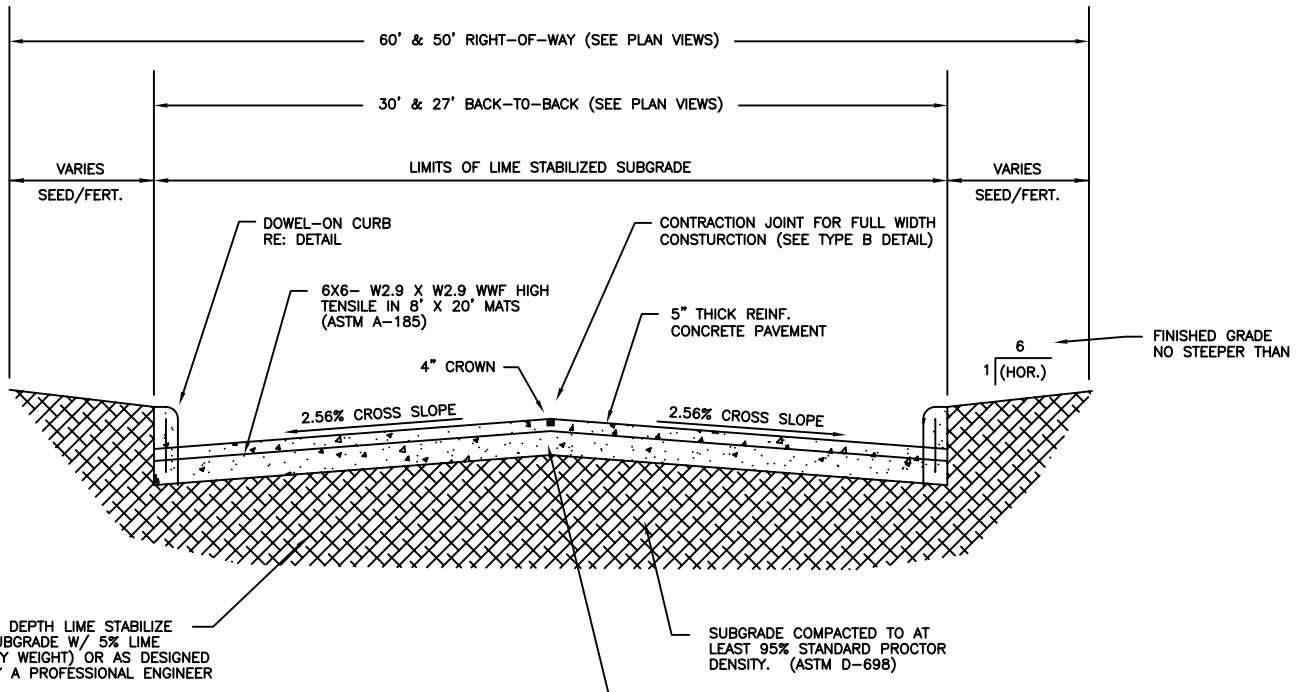
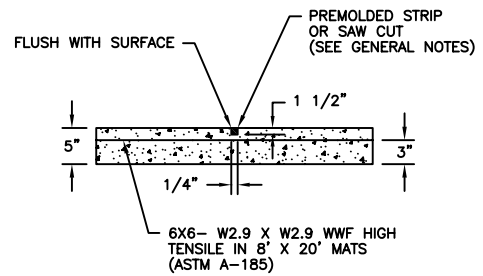

TYPE B
CONTRACTION JOINT

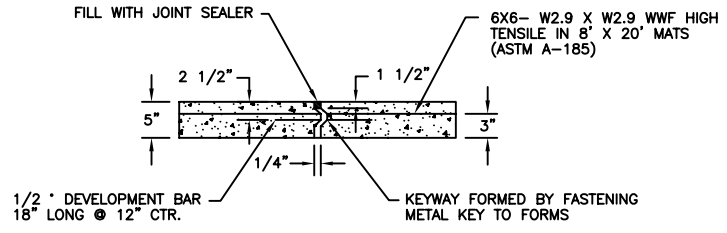

TYPE C
LONGITUDINAL CONSTRUCTION JOINT

06_EXPJT.DWG



CITY OF LUFKIN
ENGINEERING DEPARTMENT
P.O. BOX 190
LUFKIN, TEXAS 75902-0190
PHONE: (936) 633-0414

STREET STANDARDS

**EXPANSION, CONTRACTION AND
LONGITUDINAL JOINTS**

06
3-30-04